

Ultramat[®]

UFM-D03 / UFM-D05 / UFM-D10



The zero-loss condensate drain

Product description:

The UFM-D's are compressed air zero-loss, electronically controlled condensate drains.

The large internal cross-sections for draining ensure reliable operation even when dealing with dirty, particle polluted condensate: Less downtime, less trouble and more safety for the application - especially in direct comparison with time- or float controlled drains.

Additionally the condensate becomes less emulsified – when compared with time controlled solenoid valves which spray/ atomise the condensate. Less emulsification results in better function of oil/ water separators: longer compliance with legal discharge limits, less running costs!

As there is no air-loss whilst purging these drains work silent – a very important feature when this drain is installed within a working area!

The electronic control of the drain monitors the proper operation continuously. Automatic malfunction routines and a potential free contact for remote control ensures safe operation at all times. You can react to malfunctions before they are obvious by condensate water in the compressed air line at the point of use!

Service Unit:

Complete replacement of all wearing- and pressurised parts with one swift moment.

- No electrical installation required during maintenance works
- No installation of seals or single components
- Only one replacement part, function-tested by the manufacturer

Applications:

Compressed air zero-loss draining of condensate at:

- compressors
- aftercoolers
- receiver-vessels
- pre- and after-filters of fridge dryers
- pre-filters of adsorption dryers
- condensate- and oil-removal filters
- pipe bends



Service Unit



Features:	Benefits:
Electronically level-controlled	No expensive compressed air losses, condensate drain depending upon resulting condensate amount, sensor detects each kind of condensate (also pure oil), also in case of strong contamination the draining works problem-free
Electronic control	Permanent function control via LED display, automatic emergency programs in the alarm mode, potential-free alarm contact (not for UFM-D03), function test via test button
Generously dimensioned cross sections	Easy maintenance, small inclination to emulsification, small noise during draining procedure, insensitive to dirt
Service Unit	All maintenance parts in one unit, minimum expenditure with service and maintenance
Materials corrosion resistant	Aluminum corrosion-resistant, glass-fiber reinforced plastics steadily against oil-contaminated and oil-free condensate (special equipments for particularly aggressive condensate available)
Condensate inlet vertically or horizontal, with UFM-D03 and UFM-D05 with swivelling angle adapter	Flexible and easy montage on different pipings possible

Materials:	
Top (thread)	Aluminium, coated

Potential free contact (D05/D10):	
Connection data switch to load	AC: max. 250 V / 1A DC: max. 30 V / 1A
Connection data switch to low signal	min. 5 VDC / 10 mA
The switching of loads means that the properties of the contact are no longer suitable for the switching of low signals	

Option:
Bracket

Technical Data	D03	D05	D10
min./max. operating pressure	0,8 - 16 bar (12-230 psi)		
min./max. temperature	+1°C - +60°C (+34°F - +140°F)		
Condensate inlet	G 1/2 (1/2") internal	G 1/2 (1/2") internal	3x G 1/2 (1/2") internal
Condensate outlet	G 1/4 (1/4") Ø 8 - 10 mm hose connector	G 1/4 (1/4") Ø 8 - 10 mm hose connector	G 1/2 (1/2") Ø 8 - 13 mm hose connector
Condensate	oil contaminated + oil free		
Weight (empty)	0,8 kg (1.8 lbs)	1,0 kg (2.2 lbs)	1,65 kg (3.63 lbs)
max. compressor performance ¹⁾	2,5 m ³ /min (87.5 scfm)	5 m ³ /min (175 scfm)	10 m ³ /min (350 scfm)
max. fridge dryer performance ¹⁾	5 m ³ /min (175 scfm)	10 m ³ /min (350 scfm)	20 m ³ /min (700 scfm)
max. filter performance ¹⁾	25 m ³ /min (875 scfm)	50 m ³ /min (1750 scfm)	100 m ³ /min (3500 scfm)
Supply voltage (see type plate)	230 / 115 / 24 VAC ± 10%, 50-60 Hz / 24 VDC ± 10%		
Power consumption	P < 1,0 VA (W)	P < 3,0 VA (W)	P < 3,0 VA (W)
Recommended cable-jacket diameter	Ø 5,8 - 8,5 mm (0.23" - 0.34")		
Recommended wire cross-section	3x 0,75 -1,5 mm ² (0.03 - 0.06 inches squared)		
Recommended stripping of cable jacket	PE: ca. 60 mm L/N: ca. 50 mm		
Recommended length of wire end-tube	~ 6 mm (~ 0.24 inch)		
Recommended fusing	0,5 A medium time-lag		
Protection class	IP 54		

¹⁾ Max. performance for ambient temperature 20°C. 50% r. h.

Dimensions

UFM-D03

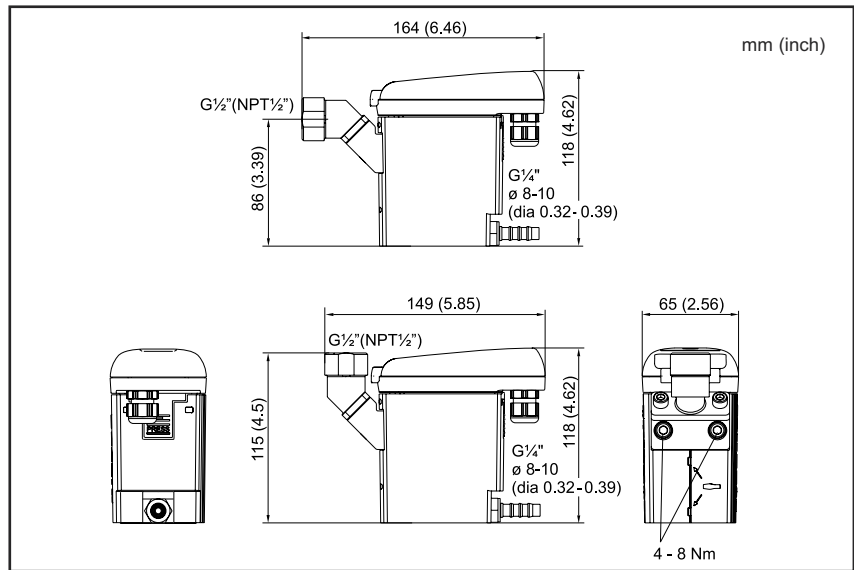

UFM-D05

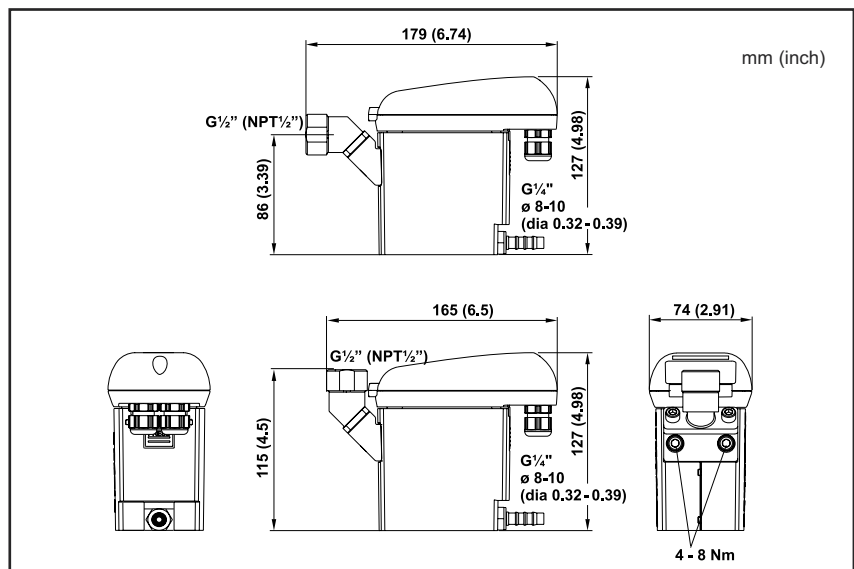

UFM-D10

